

THE INFORMATION DISCLOSED HEREIN WAS ORIGINATED BY AND IS THE PROPERTY OF MAGTROL SA. MAGTROL SA RESERVES ALL PATENT PROPRIETARY, DESIGN, USE, SALE, MANUFACTURING AND REPRODUCTION RIGHTS THERETO.

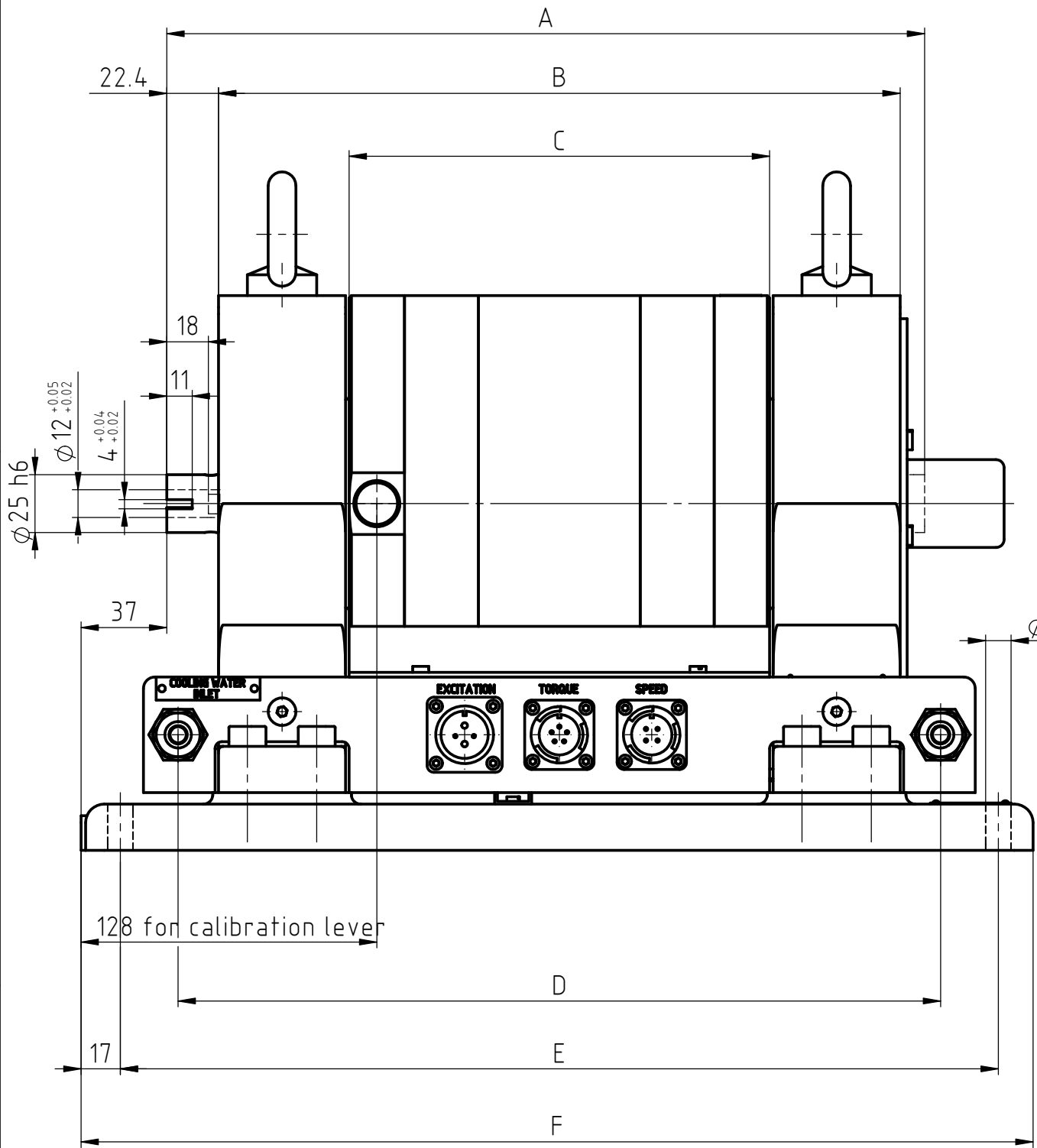

Type	A	B	C	D	E	F
1WB65-HS	258	225	112	260	310	342
2WB65-HS	328	295	182	330	380	412

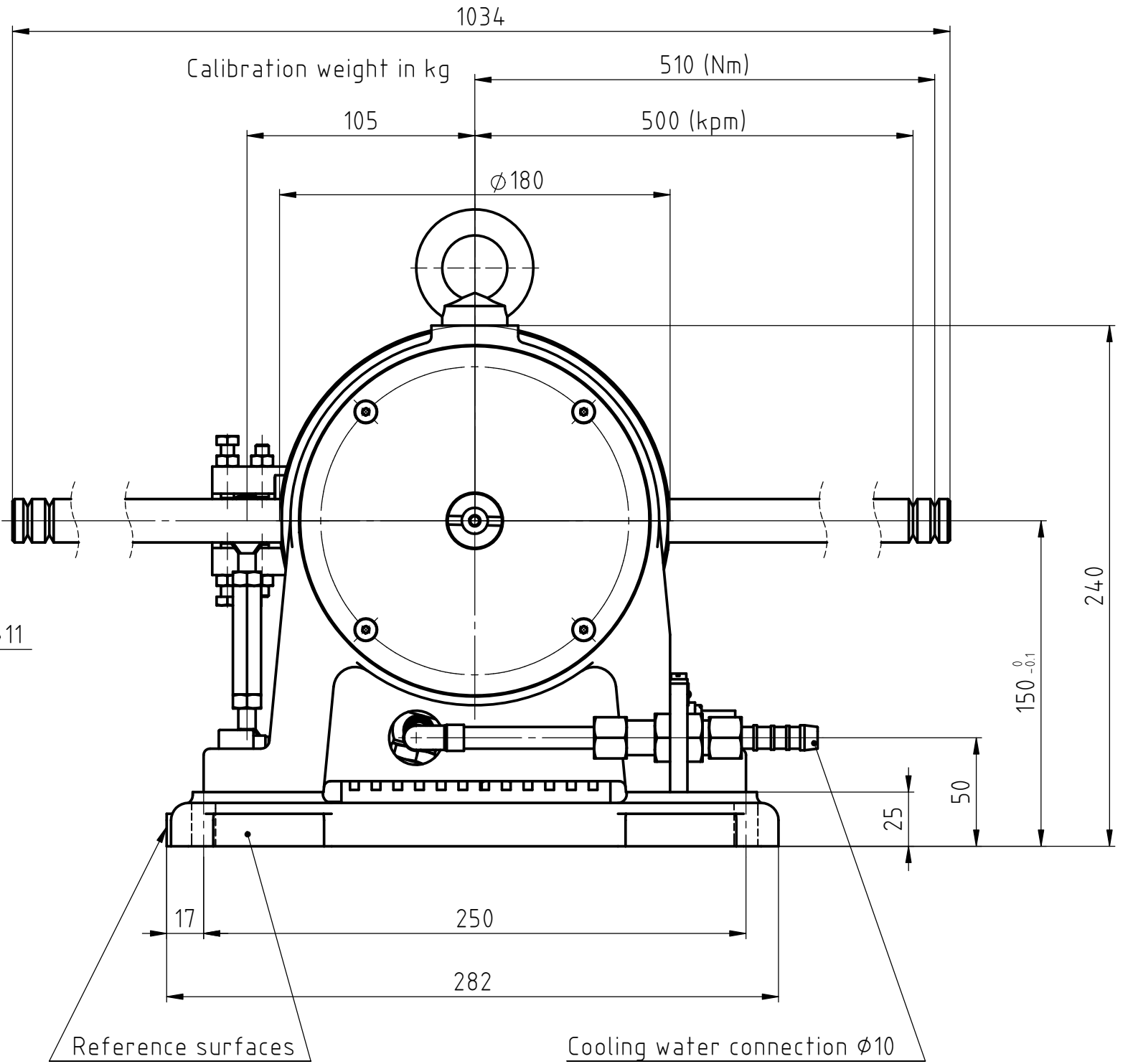

6															
5															
4															
3															
2	25.07.03	02060	A.Rappo	-----	Vorher Mass A=272 resp. 342										
1	22.03.94	-----	A.Rappo	-----	Neue Kupplungshülse; vorher Masse 4=2.7; $\phi 12=10$ ; A=264 resp. 334										
Rev.	Date	PM	Drawn	Appr.	Repl. by : Repl. for:										
Tolerances: $\pm$ mm to 50mm, $\pm$ mm over 50mm															
Material:					Scale: 1:2.5										
Finish:					<table border="1"> <tr> <td>Drawn</td> <td>22.03.94</td> <td>A.Rappo</td> </tr> <tr> <td>Checked</td> <td></td> <td></td> </tr> <tr> <td>Approved</td> <td></td> <td></td> </tr> </table>		Drawn	22.03.94	A.Rappo	Checked			Approved		
Drawn	22.03.94	A.Rappo													
Checked															
Approved															
Dynamometers 1-2WB65-HS					DRAWING N° 312-111-000V201										